

MIM10C1

MINIATURE IMAGE SENSOR MODULE

微型图像传感器模组

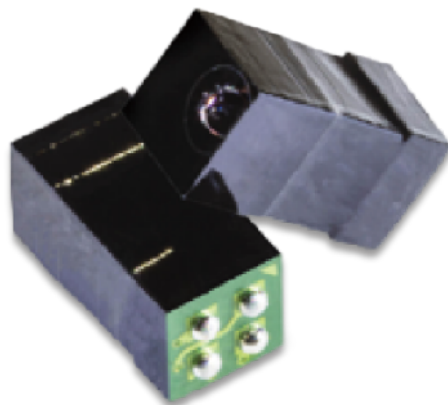

模组参数 Module Parameter

项目 Item	参数 Parameters
Active Array Size	400(H)*400(V)
Imaging Area	0.448mm*0.448mm
Package Chip size	1.04mm*1.094mm*0.66mm
Module Size (Lens+Sensor)	1.12mm*1.17mm*1.48mm
Interface	VDD, VSS, SDA/DATA+, SCL/DATA-
Lens Structure	3 Lenses
F/#	4.8
HFOV (deg)	85
VFOV (deg)	85
DFOV (deg)	120
EFL (mm)	0.253
IR filter	675nm
Relative illumination	59.90%
Depth of field	3-100mm
CRA	28.5°

市场应用 Market Application

- 临床一次性电子内窥镜
Clinical disposable electronic endoscope
- 动物医疗电子内窥镜
electronic endoscope for animal medical treatment
- 工业电子内窥镜
industrial electronic endoscope

产品结构 Product Mix

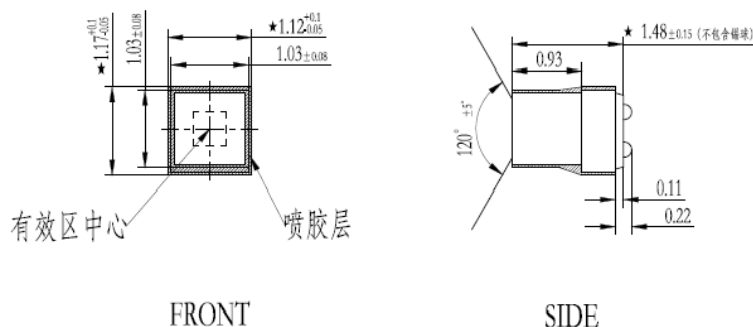

■ **Chengdu Office** (Product Center - Headquarters)
 9-10F, Unit B6-2, AI International Hub, 171# Hele 2nd street, Hi-Tech District, Chengdu, P.R.China
 TEL: 028-68669333 WEB: www.imgds.com
 E-mail: imgds@imagedesign.com

■ **Shanghai Office** (R&D Center)
 497 Gaosi Road, Zhagjiang High Tech Park, Pudong New Area, Shanghai

■ **Shenzhen Office** (Support Center)
 3F, tower t2-a, Shenzhen Software Park, No. 22, gaoxinnan 7th Road, Nanshan District, Shenzhen